

General technical data

1. BASIC CONSTRUCTION

Structure of an electrolytic aluminum capacitor is shown hereunder:

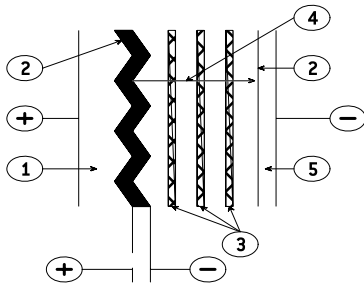

1. Anode: aluminum foil
2. Dielectric: aluminum oxide
3. Papers spacers impregnated with electrolyte
4. Ionic conduction assumed by electrolyte
5. Cathode: aluminum foil

The positive plate is an etched aluminum foil covered with alumina which is the dielectric of the capacitor.

The negative plate is constituted by a second aluminum foil which serves as a current supply, and by electrolyte-impregnated papers layers.

The metal used for anode is a $\geq 99,98\%$ grade aluminum.

The dielectric has a thickness of $13 \text{ \AA} / V$.

The aluminum used for the cathode is a $\geq 98\%$ grade aluminum covered with a dielectric layer with a thickness of about 40 \AA .

2. DIAGRAM OF THE EQUIVALENT CIRCUIT

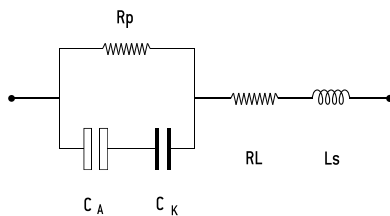

- C_A = Capacitance of the anode
- C_K = Capacitance of the cathode
- R_p = Parallel resistance due to the aluminum oxide film.
- R_L = Series resistance of connections, plates and impregnated spacer.
- L_s = Inductance of winding and connections.

A standard simplified diagram is.

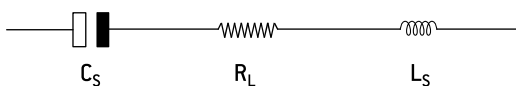

C_s is the series capacitance of both anode and cathode capacitances. Electrolytic aluminum capacitors are naturally polarized because of the insulating film on the anode. Given the very thin aluminum oxide layer, a reversed voltage should not exceed 1.5 V when there is energy supply.

Short duration reverse voltages can be absorbed by special construction, second anode replacing the former cathode.

3. CAPACITORS MARKING

3.1. ARTICLE CODE (ON EACH PACKAGING)

A followed by 6 figures number. First 3 positions are specific of the range. (Ex. A 745xxx for a FELSIC 85 BD)

140 FELSIC in bank	741 FELSIC 125 FRS BD (ex 731)
701 PRORELSIC 125	742 PRORELSIC 105 TFRS
703 PRORELSIC 125	743 PRORELSIC 105 TFRS
704 SNAPSIC	744 FELSIC 85 BC FELSIC 85 LP
705 SNAPSIC 105	745 FELSIC 85 BD
706 FELSIC HP BC – BD	746 FELSIC 85 M BC
708 PRORELSIC 145	747 FELSIC 85 M BD
710 CUBISIC	748 SICAL CO 42 - SICAL
711 PROMISIC 031	749 SICAL CO 42 - SICAL
712 CUBISIC LP	750 CUBISIC 125
713 SNAPSIC 105 LP	756 FELSIC 105 BC FELSIC 105 LP
714 SNAPSIC 4P	757 FELSIC 105 BD
715 SNAPSIC 105 4P	760 FELSIC 125
716 SNAPSIC HV	761 FELSIC HC BD
717 SNAPSIC HC	762 FELSIC 105 TFRS BC
718 SNAPSIC 125	763 FELSIC 105 TFRS BD
721 RELSIC 033	764 FELSIC HV BC
722 CI FRS	765 FELSIC HV BD
723 CI FRS	775 VACSIC
728 FELSIC 039 (ex 72?) FELSIC DI	774 VACSIC 150
738 FELSIC 037 (ex 73?)	776 ALSIC 20G ALSIC 145 20G
740 FELSIC 125 FRS BC (ex 731)	

In FELSIC ranges, article code without first letter A, is printed on each capacitor.

a Figure 9 in fourth position shows a special product.

3.2. BATCH (ON EACH CAPACITOR).

3 figures or 6 figures

3.3. DATE (ON EACH CAPACITOR IF APPLICABLE)

4 figures (year-week)

4. ELECTRICAL CHARACTERISTICS

4.1. RATED CAPACITANCE C_R

The rated capacitance is defined at 100 Hz and at ambient temperature.

4.2. RATED VOLTAGE U_R

U_R is the maximum DC voltage which may be applied in continuous operation.

When applying a superimposed alternating voltage, the peak value of the resulting waveform should not exceed the rated voltage.

4.3. PEAK VOLTAGE U_p

U_p is the maximum repetitive voltage which can be applied within short periods.

Defined in CECC 30 300 and IEC 60 384-4:

1000 cycles of 30 s charge followed by a no load period of 5 min. 30 s with upper category temperature.

$$U_p \leq 1,15 U_R \quad (U_R \leq 315 \text{ V})$$

$$U_p \leq 1,10 U_R \quad (U_R > 315 \text{ V})$$

General technical data

4.4. DISSIPATION FACTOR TANδ

The dissipation or loss factor is defined by its tangent $\text{Tan}\delta$

$$\text{Tg}\delta = R_s C_s \omega$$

$$(\omega = 2\pi F)$$

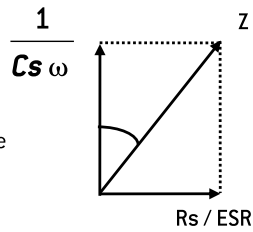

ESR Capacitor Equivalent Series Resistance

Cs Capacitor capacitance

F Frequency [100 Hz]

Z Capacitor impedance

4.5. EQUIVALENT SERIES RESISTANCE ESR

The relation between ESR and dissipation factor $\text{Tan}\delta$ is given in § 4.4.

4.6. IMPEDANCE Z - INDUCTANCE L

The impedance is given by:

$$Z = \sqrt{R^2 + \left[L\omega - \frac{1}{C\omega}\right]^2}$$

L inductance. Generally $L = 5$ to 20 nH

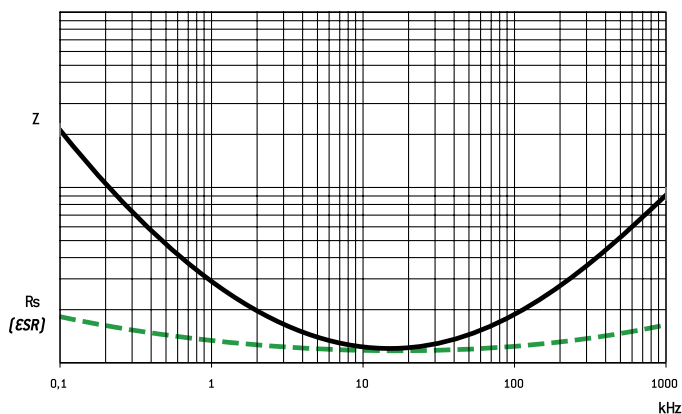

Z and ESR as function of frequency typically follows the chart:

4.7. PERMISSIBLE RIPPLE CURRENT (I r.m.s.) I~

The current is defined at the maximum climatic category and at 100 Hz. It is the root mean square value r.m.s. The value I_0 is the rated value for calculations of expected life up to $3 I_0$.

4.8. LEAKAGE CURRENT II

It is measured at 20°C after a 5 min. polarization under rated voltage.

For C_R in μF and U_R in V:

$I \leq 0,01 C_R U_R$ or $1 \mu\text{A}^*$

when $C_R U_R \leq 1000 \mu\text{C}$

$I \leq 0,006 C_R U_R + 4 \mu\text{A}$

when $C_R U_R > 1000 \mu\text{C}$

For $U_R > 350 \text{V}_{\text{DC}}$ it can be specified:

with $K = 4, 6$ or 8

or

$I \leq 0,3 (C_R U_R)^{0,7} + 4 \mu\text{A}$ (CECC 30 300)

* Whichever is the greater

4.9. CHARACTERISTICS

Versus temperature [typical values].

4.9.1. Capacitance drift

Versus temperature

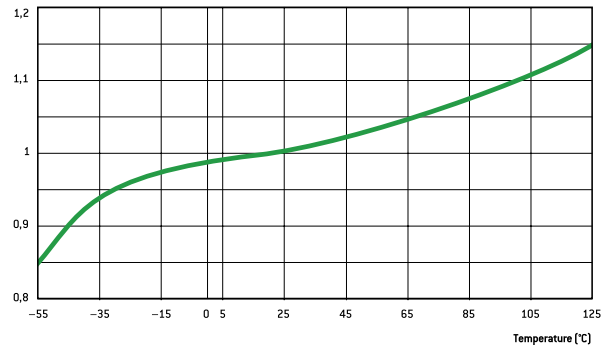

4.9.2. ESR and Z drifts at 100 Hz

Versus temperature

4.9.3 Leakage current drift

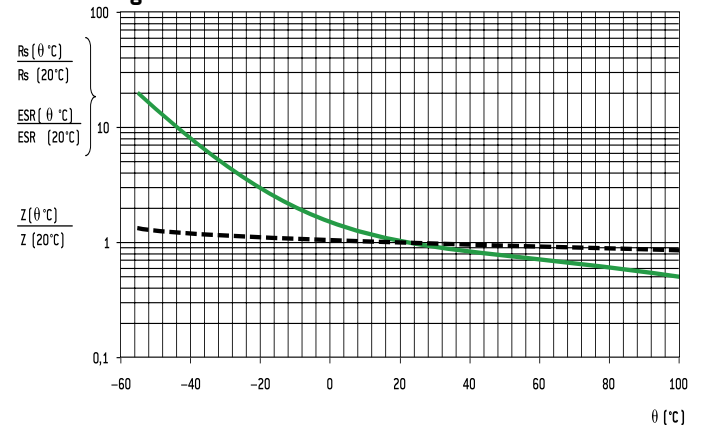

Versus temperature

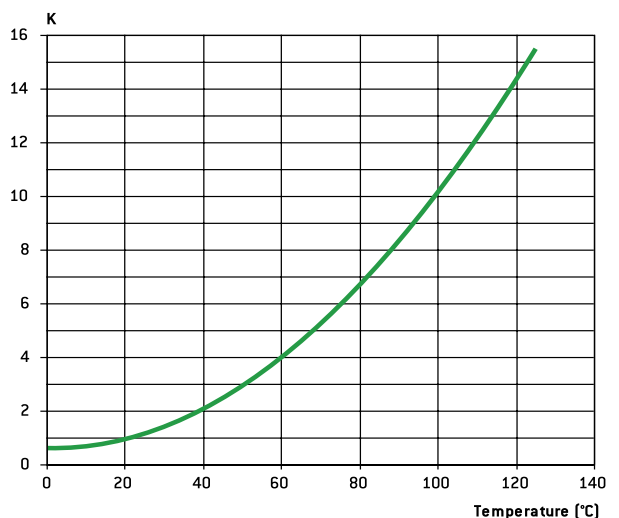

General technical data

5. SPECIFICATION TO APPLY

Electrolytic aluminum capacitors are defined in:

- NF and UTE French national standard
- CECC European specifications
- IEC international specifications

Quality insurance procedures are described in these specifications.

	French	European	International
Generic specification Fixed capacitors	NF C 83 100	CECC 30 000 EN 130 000	IEC 60 384 -1 QC 300 000
Sectional specification Electrolytic aluminum capacitors	NF C 83 110	CECC 30 300	IEC 60 384 - 4 C 300 300
Blank deta II specification - Electrolytic aluminum capacitors with non solid electrolyte.	UTE 83 110	CECC 30 301	IEC 60 384 - 4 -1 QC 300 301
Blank deta II specifications	CECC 30 301- 017 to CECC 30 301- 062 CO 31 to CO 55	CECC 30 301- 017 to CECC 30 301- 062 CECC 30 301- 802 to CECC 30 301- 811	

6. ENDURANCE TESTS / LIFE TIME

6.1. STANDARD ENDURANCE TEST

at max category temperature:

Temperature	Endurance test			
	Grade I - Long life			Grade II - General purpose
	10 000 h	5 000 h	2 000 h	1 000 h
125°C			•	
105°C		•	•	•
85°C	•	•	•	•

Standard endurance tests do not exceed 2000 hours at 125°C. However, present EXXELIA technologies concerning liquid electrolytes have led to endurance tests up to 5000 hours at 125°C (PRORELSIC 125 - FELSIC 125 RS) and even 20000 hours at 125°C (PRORELSIC 145 - ALSIC 145)

6.2. PERFORMANCE REQUIREMENTS ON STANDARD ENDURANCE TESTS.

Permissible capacitance drift $\Delta C/C$ (%)

Permissible increase factors on $\tan\delta$, ESR, Z and II initial values

U_R	Endurance test			
	Grade I			Grade II
	10 000 h	5 000 h	2 000 h	1 000 h
6,3 V			+15 -30	+25 -40
10 V - 35 V	+15 -20	± 15	± 15	± 30
40 V - 160 V	± 15	± 15	± 15	± 30
> 160 V	± 15	± 10	± 10	± 15

	Endurance test			
	Grade I			Grade II
	10 000 h	5 000 h	2 000 h	1 000 h
$\tan\delta$ or ESR [1]	1,5	1,3	1,3	1,5
Z [2]	3	2	2	3
II	Standard values			

[1] $\tan\delta$ or ESR: for initial value, take standard value.

[2] Z: for initial value, take specified value [see data sheet].

Specific requirements can be taken into consideration with regards to initial values of dissipation factor or equivalent series resistance and impedance.

6.3. FAILURE CRITERIA FOR ELECTROLYTIC CAPACITORS.

Failure criteria are defined in CECC 30 301

- Non measurable defaults leading to complete failure.
- Measurable defaults leading to adjustment losses of the load circuit (failure due to variations).

6.3.1. Non measurable defaults.

They might be summed up as:

- Open circuit
- Short circuit
- Operation of pressure relief device
- Severely damaged insulation
- Unusable terminations

6.3.2. Measurable defaults.

Variations exceeding the values given below characterize a default.

- Capacitance drift $\Delta C/C$ (%): 3 times the limit for standard endurance testing or 50 % (whichever is the smallest).
- $\tan\delta$ or ESR: 3 times standard max initial values.
- Z: 3 times standard max initial values.
- II: initial limit (under load conditions).

Specific requirements can be taken into consideration with regards to lower drifts.

6.4. INFLUENCE OF MAIN PARAMETER ON OPERATIONAL LIFE.

6.4.1. Temperature.

The capacitors operational life is highly dependent upon its internal temperature Θ_i and therefore upon the ambient temperature and the ripple current.

Knowing ESR and dissipated power values (§ 6.4.3.) one can figure out, the internal temperature rise and then determine the capacitors expected life.

With present high boiling point electrolytes (§ 8.6)

Θ_i max = 125 to 185°C depending on styles.

6.4.2. Ripple current.

The ripple current flowing through the capacitor increase the internal temperature through power dissipation.

Standards define the permissible current at 100 Hz and generally consider a temperature rise of 5 to 10°C of max category temperature.

Current waveforms and frequencies make it difficult to clearly determine the capacitors internal temperature rise, which defines the operationally life.

Experiments confirm following relationship:

$$\Theta_i = \Theta_a + (\Theta_c - \Theta_a) K$$

Where:

- Θ_i = Internal hot spot temperature
- Θ_a = Ambient temperature
- Θ_c = Case temperature
- K = Parameter depending upon case diameter and cooling
 - $\emptyset \geq 51$ k = $2 \pm 0,5$
 - $\emptyset < 51$ k = $1,5 \pm 0,5$ (air cooling - 0,2 m/s)

General technical data

r.m.s. value according to current waveform.

Function	Mean value	R.m.s. value	Function	Mean value	R.m.s. value	Function	Mean value	R.m.s. value
	$A (t_0/T)$	$A \sqrt{t_0/T}$		$A/2$	$A \sqrt{3}$		$2A/\pi$	$A / \sqrt{2}$
	$A (t_1/T)$	$A \sqrt{2t_1/3T}$		$2A/\pi (t_0/T)$	$A \sqrt{t_0/2T}$		$A/2$	$A / \sqrt{3}$
	$A/2 (t_0/T)$	$A \sqrt{t_0/3T}$		$A/2 (t_0/T)$	$A \sqrt{t_0/3T}$		0	A

6.4.3. Dissipated power versus case dimension

For calculations of ripple currents, considering an internal temperature rise of 10°C

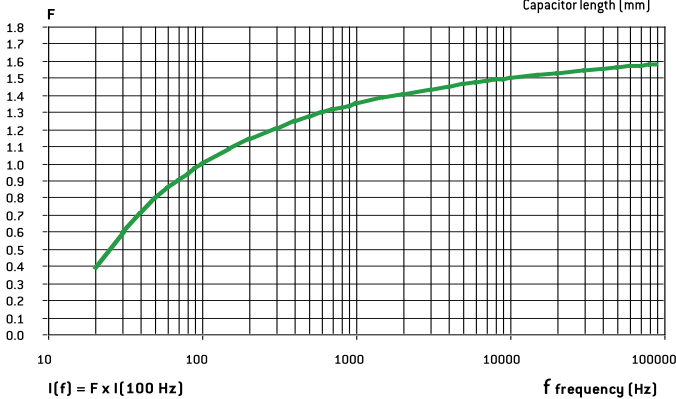
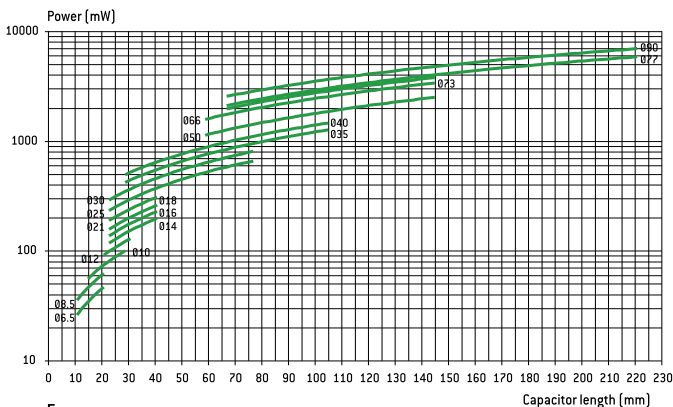

$P = ESR \cdot I^2$

P = Dissipated power (mW)

($\Theta_i - \Theta_a = 10^\circ\text{C}$)

ESR: Equivalent series resistance (100 Hz 20°C)

I: Ripple current (r.m.s. value at 100 Hz)

For different frequencies from 100 Hz, I must be multiplied by the factor F, according to above chart.:

6.4.4. Thermal resistance Rth and air cooling

Rth is static thermal resistance (without cooling) between capacitor central hot spot and ambient temperature measured at a distance of one capacitor diameter

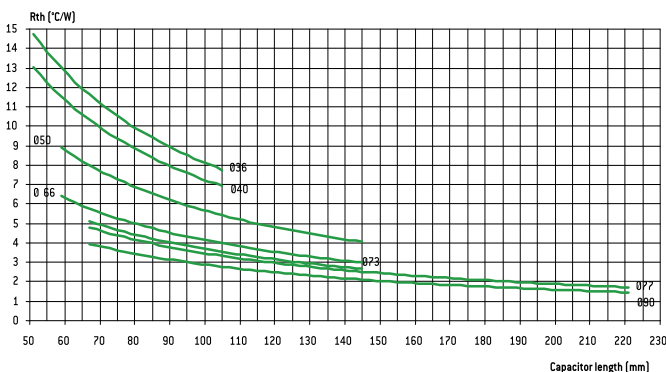

Forced or not cooling air can lead to a significant decrease of these values.

Consequently, r.m.s. ripple current can be increased as a function of air cooling speed:

Ø mm (inches)	≤ 0,5 m/s	1 m/s	2 m/s	3 m/s	≥ 4 m/s
66 - 90	1~	1,1~	1,2~	1,25~	1,3~
36 - 51	1~	1,2~	1,4~	1,45~	1,5~

This parameter shall be applied to one capacitor alone.

For capacitors in bank, ambient temperature must be strictly equal around all capacitors.

6.4.5. Quality guaranty

We guarantee products manufactured during 2 years from the data of shipment against defaults of material and assembly.

This guaranty can be involved by the buyer only if our products are used within normal conditions, always according to the state of the art and taking in account storage conditions.

The equipment design should take into consideration possible failures of our capacitors and related effects in order to avoid them.

Guaranty is not applicable for damages occurred by surge voltage, irregular use, polarity inversion or maintenance default.

Guaranty is exclusively limited to the replacement of individual defective capacitors within the terms of delivery. This rule applied to all cases and particularly to any further consequence of failures.

6.4.6. Reliability

Failure rate:

$$FR = \frac{\text{Number of components tested} \times \text{test duration}}{\text{Number of failures}}$$

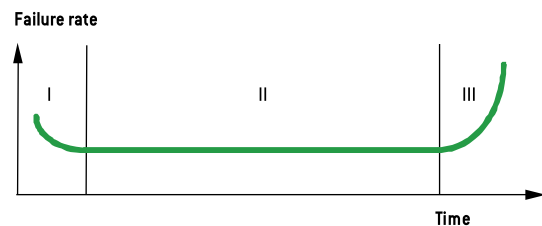

Failure rate is measured in FIT (failure in time = 10^{-9} / hour).

The failure rate is set up during the life time of the capacitor (phase II)

I. Early failure phase (generally excluded during ageing process).

II. Operational life time of the capacitors

III. End of life

General technical data

Mean time between failures MTBF = 1/FR mesured in years

Range	Failure rate for a failure percentage not exceeding 1% with a confidence level of 60 %
FELSIC 85 >350 V FELSIC HC > 350 V SNAPSIC - SNAPSIC HC > 350 V SNAPSIC 4P > 350 V PROMISIC 031 Ø = 6,5 SICAL CO 42 - SICAL > 350 V	50 FIT - (MTBF = 2280)
FELSIC 037 - 039 FELSIC 85 ≤ 350 V FELSIC HC ≤ 350 V CUBISIC CI FRS SNAPSIC 105 - SNAPSIC 105 4P SNAPSIC 105 LP - SNAPSIC HV SNAPSIC - SNAPSIC 4P ≤ 350 V SNAPSIC HC ≤ 350 V ALSIC IR - ALSIC 145 - ALSIC HV - VACSIC 150 - VACSIC SICAL CO 42 - SICAL ≤ 350 V PRORELSIC 125 Ø = 6,5 RELSIC 033 PROMISIC 031 Ø > 6,5	25 FIT - (MTBF = 4560)
FELSIC 125 FRS - SNAPSIC 125 FELSIC HV - FELSIC 105	10 FIT - (MTBF = 11410)
PRORELSIC 125 Ø > 6,5 PRORELSIC 145	5 FIT - (MTBF = 22820)

Multiplying factor of FR with voltage and temperature

Factor	Temperature [°C]							
	≤ 40	50	60	70	85	105 (1)	125 (1)	145 (1)
Factor	1	1,5	2,3	3,4	6,3	14	32	72

(1) Only for permitted capacitors

Factor	Percentage of rated voltage (2)		
	100 %	80 %	50 %
Factor	1	0,8	0,5

(2) This voltage has to be constant

Environ- ment	Without vibration		Ground with vibrations or mob Ile			
	Ground, fix Controlled air	Ground, fix	PRORELSIC SNAPSIC 20 g FELSIC 20 g	FELSIC 10 g PROMISIC SICAL Ø ≤14	CI FRS - SNAPSIC RELSIC SICAL Ø >14	ALSIC
Factor	1	2	2	4	6	12

7. MANUFACTURING FLOW CHART

Process controls

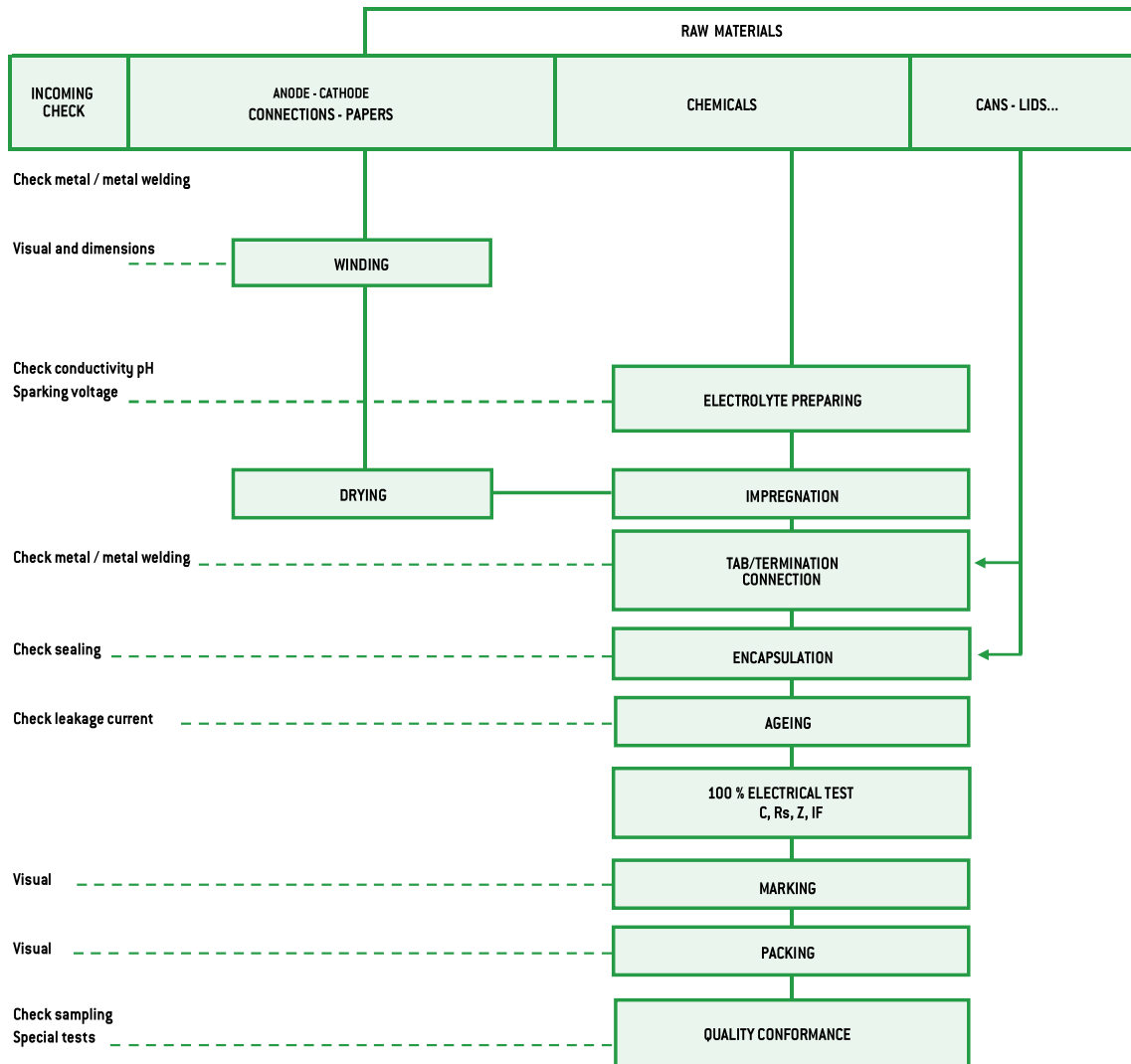

General technical data

8. INFORMATION ON APPLICATION

8.1. CLEANING SOLVENTS

Use aliphatic alcohols, such as denatured ethyl alcohol, isopropanol, or butylacetate, or else alkaline diluted solutions. Avoid incompatible solvents (halogenous for example).

8.2. SHELF LIFE

There is no electrical characteristics variation for long periods of storage except leakage current which can increase.

It is caused by chemical reactions between the dielectric alumina and the electrolyte. These reactions are reversible when switched on. Capacitors can generally be stored at temperature between -5° and $+50^{\circ}\text{C}$ without reforming for the following periods of time:

- For $U_R \leq 100\text{ V}$, storage time: 5 years (up to 10 years under specific conditions)
- For $100\text{ V} < U_R \leq 360\text{ V}$ storage time: 3 years
- For $360\text{ V} < U_R < 500\text{ V}$ storage time: 1 year
- For $U_R \leq 500\text{ V}$, storage time: 6 months

Generally when these periods are overstepped, one hour at rated voltage causes the decrease of leakage current under the specified limits. An other way to avoid this leakage current increase problem is to always limit available power through capacitor during first seconds or minutes after storage or transport, according to the following chart:

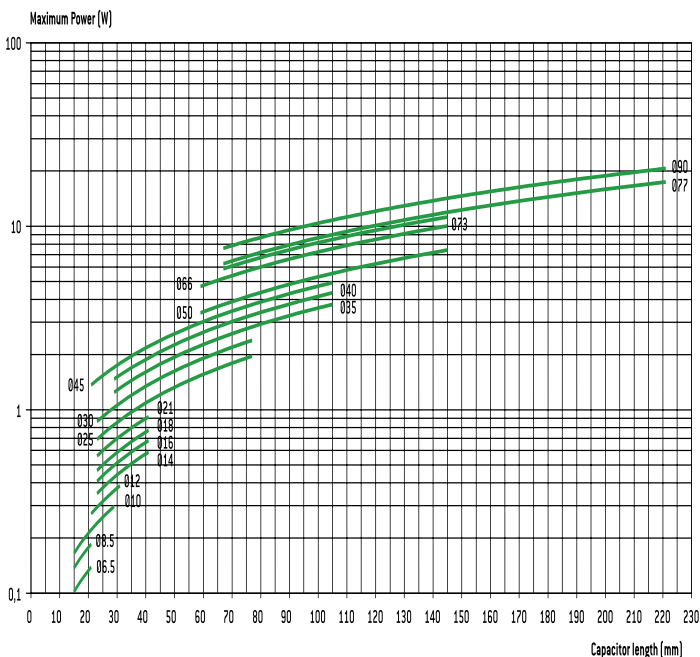

8.3. LOW PRESSURE RESISTANCE

EXXELIA capacitors can be used with ambient low pressure decreasing up to 10 mbar (altitude 28000 m – 92000 feet).

8.4. MOUNTING SCREW TERMINALS CAPACITORS (FELSIC)

Capacitors may be used vertically (terminals on top) or horizontally. When used horizontally, the following position in relation to the safety vent, is recommended:

Mounting capacitors in series may be used for operating voltage exceeding U_R . See FELSIC in bank.

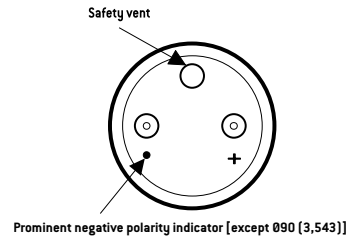

8.5. MOUNTING SOLDER TYPE CAPACITORS.

They may be used in any position. During mounting, avoid applying excessive force to capacitor pins or wires. There is a risk of damaging internal connections.

After soldering and for the same reasons, do not try to move the capacitor's body.

8.6. ELECTROLYTES: SAFETY RULES.

Electrolytes used in EXXELIA capacitors are manufactured by EXXELIA. Main solvents are generally γ butyrolactone and ethylene glycol, very stable high boiling point solvents. Ionic conductive salts in electrolyte induce a very weak acidity (pH 5 to 7).

8.7. ENVIRONMENT.

In aluminium capacitors with liquid electrolyte there is no component showing a pollution risk, in small amounts, of air or water. EXXELIA is always involved in this security field particularly in using chemicals for electrolyte, without well-known risks.

- Dimethylformamide (DMF) dangerous solvent forbidden in several uses is completely excluded by EXXELIA, since 1990.
- There is no halogen compound such as chlorofluorocarbon (CFC or FCKW in german) or polychlorobiphenyl (PCBPyralene) or pentabromodiphenylether or octabromodiphenylether.

There is neither benzene, toluene or phenyl compound nor explosive such as picric acid, nor asbestos in plastic covers. All the capacitors made by EXXELIA since 1991, can be scrapped or used in raw materials recycling processes without special care in compliance with Community rules.

EXXELIA aluminium capacitors with non-solid electrolyte are particularly suitable for different kinds of environment taking in account severity increasing laws.

European directives 2003/11/EC, 2002/96/EC (WEEE) and 2002/95/EC (RoHS) applies to all EXXELIA capacitors including every solder type, manufactured with pure tin coated pins or wires, since at least January 2006.

Mounting and insulating parts

STUD FIXING: FELSIC BD

Steel nut, spring washer and insulating washer are delivered loosely with the capacitor.

STANDARD MOUNTING WITH:

Insulating washer and steel nut

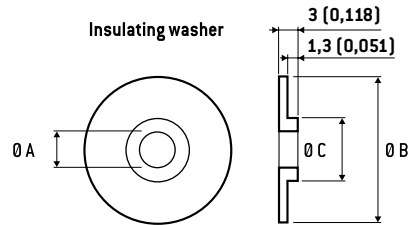
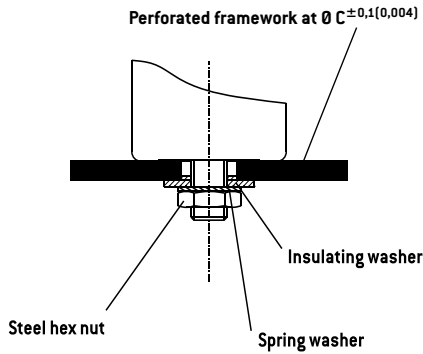

Ø Capacitor	DIMENSIONS in mm (inches)				
	M	Ø A	Ø B	Ø C	Code
36	8	8,4	25	18,5	A 691060
51 - 77	12	12,5	30	21,5	A 691061
90	12	12,5	35	21,5	A 691062

Insulating plastic nut with or without insulating washer

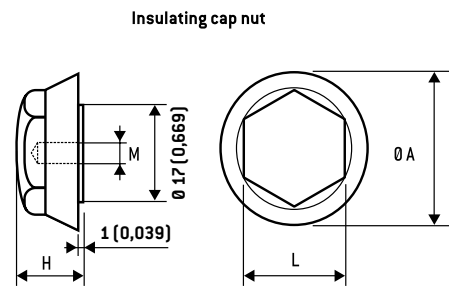
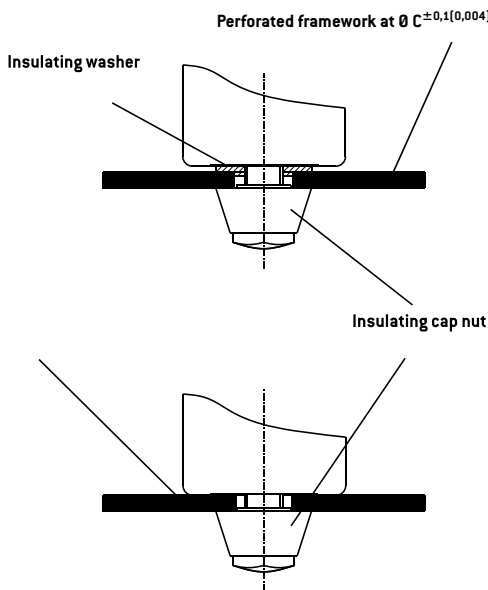

DIMENSIONS in mm (inches)					
M	Ø A	H	L	Max. torque	Code
8 [0,315]	25 [0,984]	15 [0,591]	17 [0,669]	3 Nm	A 691070
12 [0,472]	30 [1,181]	20 [0,787]	19 [0,748]	7 Nm	A 691071

Ring - clip mounting: FELSIC LP

Ring clips shall be ordered separately.

Tightening screws and nuts are supplied loosely.

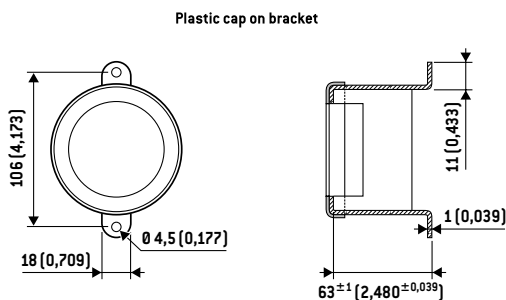

FELSIC 85 LP FELSIC 105 LP	Code
Metal bracket	A691055
Plastic cap	A691065

General technical data

Ring - clip mounting: FELSIC BC

Ring clips shall be ordered separately.

Tightening screws and nuts are supplied loosely.

FELSIC BC - Metal ring-clips

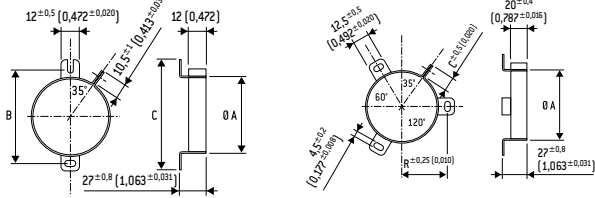

Ø A Cap.	B	C	Code	Ø A Cap.	B	C	Code
36 (1,417)	54 (2,126)	63 (2,480)	A 691901	51 (2,008)	33,5 (1,319)	11,8 (0,465)	A 691905
				66 (2,598)	39 (1,535)	10,5 (0,413)	A 691913
				73 (2,874)	44 (1,732)	10,5 (0,413)	A 691914
				77 (3,031)	44,5 (1,752)	10,5 (0,413)	A 691907
				90 (3,543)	53,3 (2,098)	11,8 (0,465)	A 691915

Stirrup mounting: CUBISIC LP

Stirrups shall be ordered separately.

Tightening screws and nuts are supplied loosely

Salt mist endurance of screws and mounting accessories:
minimum 96 h (IEC 600 68-2-11)

CUBISIC /CUBISIC LP - Metal bracket

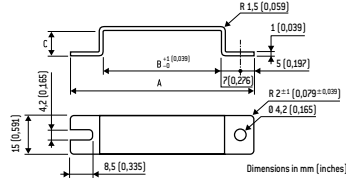

Ø A Cap.	A	B	C	Code
45x12 (1,772x0,472)	69 (2,717)	45 (1,772)	10 (0,394)	A 691057
35x16 (1,378x0,630)	59 (2,323)	35 (1,378)	14 (0,551)	A 691059

PACKAGING

1. PACKAGING AND WEIGHT UNITS.

1.1. Capacitor with screw terminals

Can DIMENSIONS in mm (inches)				Unit weight *
Ø	H			(g)
36 (1,417)	47 (1,850)	52 (2,047)	53 (2,087)	70
36 (1,417)	60 (2,362)			79
36 (1,417)	80 (3,150)	81 (3,189)		100
36 (1,417)	104 (4,094)	105 (4,134)		120
51 (2,008)	47 (1,850)			80
51 (2,008)	62 (2,441)	63 (2,480)		105
51 (2,008)	81 (3,189)	82 (3,228)		190
51 (2,008)	104 (4,094)	105 (4,134)		260
51 (2,008)	112 (4,409)			270
51 (2,008)	144 (5,669)			370
66 (2,598)	104 (4,094)	105 (4,134)		430
66 (2,598)	112 (4,409)			460
73 (2,874)	104 (4,094)	112 (4,409)		600
73 (2,874)	144 (5,669)			680
77 (3,031)	104 (4,094)	105 (4,134)		620
77 (3,031)	144 (5,669)	145 (5,709)		860
77 (3,031)	200 (7,874)			1300
77 (3,031)	220 (7,874)	221 (8,701)		1400
90 (3,543)	67 (2,638)			600
90 (3,543)	144 (5,669)	145 (5,709)		1400
90 (3,543)	200 (7,874)			1800

* Unit weight = typical values

Possible variations of = ± 25 % according to different voltage and capacitance.

1.2. Radial solder types

Can dimensions mm (inches)			ALSIC	SNAP-SIC	Can dimensions			ALSIC	SNAP-SIC
Ø	H	Weight* (g)			Ø	H	Weight* (g)		
10 (0,394)	16 (0,630)	1,8	-		35 (1,378)	30 (1,181)	-	50	
12,5 (0,492)	21 (0,827)	4,5	-		35 (1,378)	40 (1,575)	-	50	
12,5 (0,492)	24 (0,945)	5	-		35 (1,378)	45 (1,772)	-	52	
					35 (1,378)	50 (1,969)	-	60	
16 (0,630)	25 (0,984)	8,2	-		35 (1,378)	75 (2,953)	-	95	
					35 (1,378)	100 (3,937)	-	125	
22 (0,866)	25 (0,984)	-	15		40 (1,575)	40 (1,575)	-	65	
22 (0,866)	30 (1,181)	-	17		40 (1,575)	50 (1,969)	-	100	
22 (0,866)	40 (1,575)	-	18		40 (1,575)	75 (2,953)	-	130	
					40 (1,575)	100 (3,937)	-	170	
25 (0,984)	25 (0,984)	-	17		45 (1,772)	21 (0,827)	-	50	
25 (0,984)	30 (1,181)	-	20		45 (1,772)	(0,984)	-	60	
25 (0,984)	35 (1,378)	-	22		45 (1,772)	30 (1,181)	-	73	
25 (0,984)	40 (1,575)	-	25		45 (1,772)	35 (1,378)	-	85	
25 (0,984)	45 (1,772)	-	28		45 (1,772)	45 (1,772)	-	110	
25 (0,984)	50 (1,969)	-	30		45 (1,772)	75 (2,953)	-	180	
					45 (1,772)	100 (3,937)	-	240	
30 (1,181)	25 (0,984)	-	28						
30 (1,181)	30 (1,181)	-	30						
30 (1,181)	35 (1,378)	-	30						
30 (1,181)	40 (1,575)	-	40						
30 (1,181)	45 (1,772)	-	45						
30 (1,181)	50 (1,969)	-	50						

Can DIMENSIONS in mm (inches)			CUBISIC
I	L	H	weight (g)
35 (1,378)	35 (1,378)	16 (0,630)	30
35 (1,378)	50 (1,969)	16 (0,630)	40
45 (1,772)	35 (1,378)	12 (0,472)	30
45 (1,772)	50 (1,969)	12 (0,472)	45
45 (1,772)	75 (2,953)	12 (0,472)	60

* Unit weight = typical values

Possible variations of = ± 25 % according to different voltage and capacitance.

1.3. Axial types

Can DIMENSIONS in mm (inches)		PRORELSIC	PRORELSIC	SICAL CO 42
Ø	H	Unit weight * (g)	Unit weight * (g)	Unit weight * (g)
6,5 (0,256)	15 (0,591)	-	1,6	-
6,5 (0,256)	19 (0,748)	-	1,8	1,8
8,5 (0,335)	19 (0,748)	-	2,3	2,3
10 (0,394)	19 (0,748)	-	2,8	2,8
10 (0,394)	25 (0,984)	-	3,5	3,5
10 (0,394)	28 (1,102)	-	3,8	-
12 (0,472)	25 (0,984)	-	5	-
12 (0,472)	30 (1,181)	-	5,4	5,4
14 (0,551)	30 (1,181)	-	6,9	6,9
14 (0,551)	41 (1,614)	-	9,5	-
(0,630)	30 (1,181)	7,7	-	7,7
18 (0,709)	35 (1,378)	13,6	-	-
18 (0,709)	40 (1,575)	15,3	-	15,3
21 (0,827)	40 (1,575)	19,5	-	19,5
25 (0,984)	40 (1,575)	28	-	28
25 (0,984)	50 (1,969)	35	-	35
25 (0,984)	75 (2,953)	56	-	56

* Unit weight = typical values

Possible variations of = ± 25 % according to different voltage and capacitance.

General technical data

2. PACKAGING ON TAPE

2.1. Axial types

Dimensions and tolerance in accordance with IEC 60 286-

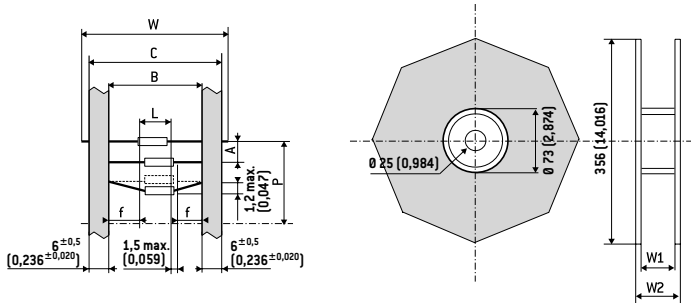

DIMENSIONS in mm (inches)									
D	L max.	B	A	P	C max.	W ₁	W ₂ max.	W	n ⁽²⁾
6,5 (0,256)	20 (0,787)	73 ± 1,5 (2,874 ± 0,059)	10 ± 1,5 (0,394 ± 0,059)	± 2 (0,079)	87,5 (3,445)	93 (3,661)	106 (3,661)	85 ± 1,5 (3,346 ± 0,059)	1000 (39,370)
8,5 (0,335) ⁽¹⁾								750 (29,528)	
10 (0,394) ⁽¹⁾	32 (1,260)	73 ± 1,5 (2,874 ± 0,059)	15 ± 1,5 (0,591 ± 0,059)	± 3 (0,118)	87,5 (3,445)	93 (3,661)	106 (3,661)	85 ± 1,5 (3,346 ± 0,059)	400 (15,748)
12 (0,472) ⁽¹⁾									400 (15,748)
14 (0,551) ⁽¹⁾									200 (7,874)

(1) On tape only on request

(2) n = number of capacitors per reel.

White positive tape f : > 20 mm (0,787 inches)

P: 10 space



FELSIC HC

BC - BD

8 000 h / 85°C

10 V ... 500 V	100 µF ... 3 121 000 µF	Ø 36 [1,417] ... Ø 90 [3,543]	- 40°C + 85°C	Long Life Time
----------------	-------------------------	-------------------------------	---------------	----------------



APPLICATIONS

- Power electronics: converters, current inverters
- Switch mode power supplies
- Magnetization, welding machines, flash

Fixing: Clip or stud fixing

Screw terminals: M5 or M6

Tolerance on capacitance at 20°C : ±20 %

Operating temperature : - 40°C + 85°C

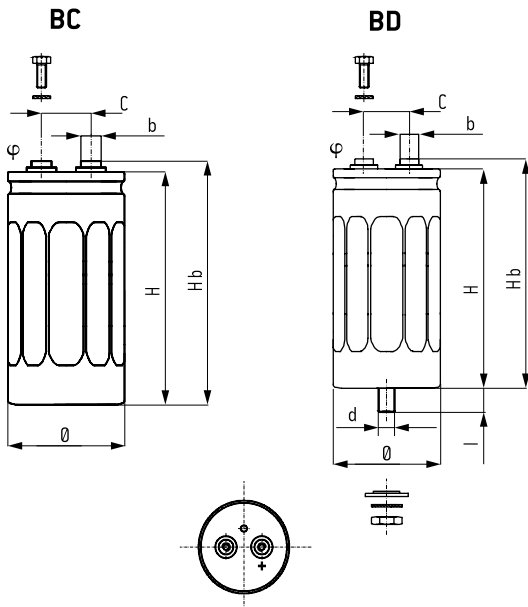

BC	BD
Insulated aluminum can	Aluminum can with sleeve
Hexagonal screws	Hexagonal screws
Spring washers	Spring washers
Fixing clip must be ordered separately	Stud fixing delivered with capacitor (steel hex nut, spring washer)

DIMENSIONS in mm (inches)

Ø ±1 (0,039)	H ±2 (0,079)	Hb ±2 (0,079)	c ±0,5 (0,020)	Φ	b
36 [1,417]	44 [1,732]	50 [1,969]	12,7 [0,500]	M5	8 [0,315]
36 [1,417]	52 [2,047]	58 [2,283]	12,7 [0,500]	M5	8 [0,315]
36 [1,417]	60 [2,362]	66 [2,598]	12,7 [0,500]	M5	8 [0,315]
36 [1,417]	80 [3,150]	86 [3,386]	12,7 [0,500]	M5	8 [0,315]
36 [1,417]	104 [4,094]	110 [4,331]	12,7 [0,500]	M5	8 [0,315]
51 [2,008]	62 [2,441]	68 [2,677]	22,2 [0,874]	M5	13 [0,512]
51 [2,008]	81 [3,189]	87 [3,425]	22,2 [0,874]	M5	13 [0,512]
51 [2,008]	104 [4,094]	110 [4,331]	22,2 [0,874]	M5	13 [0,512]
51 [2,008]	144 [5,669]	150 [5,906]	22,2 [0,874]	M5	13 [0,512]
66 [2,598]	104 [4,094]	110 [4,331]	28,5 [1,122]	M5	13 [0,512]
73 [2,874]	104 [4,094]	110 [4,331]	31,7 [1,248]	M5	13 [0,512]
73 [2,874]	144 [5,669]	150 [5,906]	31,7 [1,248]	M5	13 [0,512]
77 [3,031]	104 [4,094]	110 [4,331]	31,7 [1,248]	M5	13 [0,512]
77 [3,031]	144 [5,669]	150 [5,906]	31,7 [1,248]	M5	13 [0,512]
77 [3,031]	220 [8,661]	226 [8,898]	31,7 [1,248]	M5	13 [0,512]
90 [3,543]	144 [5,669]	151 [5,945]	31,7 [1,248]	M6	13 [0,512]
90 [3,543]	200 [7,874]	207 [8,150]	31,7 [1,248]	M6	13 [0,512]

Ø	d	l	Max. nut torque
36 [1,417]	M8	12 ^{±1} [0,472 ^{±0,472}]	4 Nm
≥ 51 [2,008]	M12	16 ^{±1,5} [0,630 ^{±0,059}]	10 Nm

HEXAGONAL SCREWS mm (inches)

Screwing height between screws and terminals:
3,5 [0,138] max

Max. screw torque: M5: 3 Nm [x min 8 [0,315]]
M6: 6 Nm [x min 10 [0,394]]

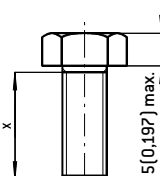

SPECIFICATIONS

NFC 83 110 - long life

DIN 41 240 - Climatic category GPF

- 40°C + 85°C / 56 days

CECC 30 300

IEC 60 384.4 long life

Standard endurance test at U_R: 2000 h / 85°C

RESISTANCE TO VIBRATIONS

Hb mm (inches)	>150 [5,906]	≤150 [5,906]
f [Hz]	10 - 55 Hz	10 - 2000 Hz
Amplitude	0,75 [0,030]	1,5 [0,059]
Acceleration	10 g - 98 m/s ²	20 g - 196 m/s ²
t (h)	3 x 2 h	3 x 2 h

WITHSTAND STRENGTH OF INSULATING SLEEVE

Insulation resistance at 20°C between terminals and mounting hardware: 100 MΩ

Test voltage at 50 Hz 1 min. between terminals

and mounting hardware: 2000 V

Fire resistance: self extinguish 15 s (IEC 60 695-2-2)

8 000 h / 85°C

Capacitance (μF)	Can		ESR 100 Hz +20°C		Z 10 kHz +20°C Typic ($\text{m}\Omega$)	II +20°C 5 min max. (mA)	I~ 100 Hz		Code			
	\emptyset mm (inches)	H mm (inches)	Typic ($\text{m}\Omega$)	max. ($\text{m}\Omega$)			+40°C max. (A)	+85°C max. (A)	BC	BD		
Rated voltage 10 V												
50000	36	(1,417)	44	(1,732)	33	52	32	4,2	11,7	6,7	A777001	A778001
74000	36	(1,417)	52	(2,047)	22	36	22	5,5	15,2	8,7	A777002	A778002
80000	36	(1,417)	60	(2,362)	20	33	20	5,8	16,9	9,7	A777003	A778003
130000	36	(1,417)	80	(3,150)	13	22	12	8,2	22,0	14,0	A777004	A778004
174000	36	(1,417)	104	(4,094)	9	17	9	10,1	22,0	18,2	A777005	A778005
183000	51	(2,008)	62	(2,441)	11	19	11	10,4	25,0	13,9	A777006	A778006
296000	51	(2,008)	81	(3,189)	7	13	7	14,6	25,0	19,8	A777007	A778007
395000	51	(2,008)	104	(4,094)	5	11	5	17,9	25,0	25,0	A777008	A778008
593000	51	(2,008)	144	(5,669)	3	8	3	23,7	25,0	25,0	A777009	A778009
664000	66	(2,598)	104	(4,094)	5	10	5	25,7	50,0	25,1	A777010	A778010
837000	73	(2,874)	104	(4,094)	4	8	4	30,2	55,0	31,4	A777011	A778011
1255000	73	(2,874)	144	(5,669)	2	7	2	40,1	55,0	44,3	A777012	A778012
972000	77	(3,031)	104	(4,094)	4	9	4	33,5	55,0	30,8	A777013	A778013
1458000	77	(3,031)	144	(5,669)	2	7	2	44,5	55,0	43,4	A777014	A778014
2272000	77	(3,031)	220	(8,661)	2	7	2	60,7	55,0	55,0	A777015	A778015
2081000	90	(3,543)	144	(5,669)	2	6	2	57,1	80,0	49,8	A777016	A778016
2774000	90	(3,543)	200	(7,874)	2	6	2	69,9	80,0	66,2	A777017	A778017
3121000	90	(3,543)	220	(8,661)	2	6	2	75,9	80,0	72,6	A777018	A778018
Rated voltage 16 V												
39000	36	(1,417)	44	(1,732)	33	53	33	4,9	11,6	6,7	A777019	A778019
57000	36	(1,417)	52	(2,047)	23	37	22	6,4	15,1	8,7	A777020	A778020
62000	36	(1,417)	60	(2,362)	21	34	21	6,8	16,8	9,7	A777021	A778021
101000	36	(1,417)	80	(3,150)	13	22	13	9,6	22,0	14,0	A777022	A778022
135000	36	(1,417)	104	(4,094)	10	17	10	11,7	22,0	18,2	A777023	A778023
142000	51	(2,008)	62	(2,441)	11	20	11	12,1	25,0	14,1	A777024	A778024
230000	51	(2,008)	81	(3,189)	7	13	7	17,0	25,0	20,2	A777025	A778025
306000	51	(2,008)	104	(4,094)	5	11	5	20,7	25,0	25,0	A777026	A778026
460000	51	(2,008)	144	(5,669)	3	8	3	27,6	25,0	25,0	A777027	A778027
515000	66	(2,598)	104	(4,094)	5	10	5	29,9	50,0	25,9	A777028	A778028
649000	73	(2,874)	104	(4,094)	4	8	4	35,1	55,0	32,3	A777029	A778029
974000	73	(2,874)	144	(5,669)	2	7	2	46,7	55,0	45,6	A777030	A778030
754000	77	(3,031)	104	(4,094)	4	8	4	39,0	55,0	31,8	A777031	A778031
1131000	77	(3,031)	144	(5,669)	2	7	2	51,8	55,0	44,8	A777032	A778032
1762000	77	(3,031)	220	(8,661)	2	7	2	70,6	55,0	55,0	A777033	A778033
1613000	90	(3,543)	144	(5,669)	2	6	2	66,4	80,0	51,5	A777034	A778034
1434000	90	(3,543)	200	(7,874)	2	7	2	61,2	80,0	72,3	A777035	A778035
2151000	90	(3,543)	200	(7,874)	2	6	2	81,2	80,0	67,8	A777036	A778036
2420000	90	(3,543)	220	(8,661)	2	6	2	88,2	80,0	74,6	A777037	A778037
Rated voltage 25 V												
27000	36	(1,417)	44	(1,732)	34	54	33	5,2	11,5	6,6	A777038	A778038
40000	36	(1,417)	52	(2,047)	23	37	23	6,8	15,0	8,6	A777039	A778039
43000	36	(1,417)	60	(2,362)	21	34	21	7,2	16,6	9,6	A777040	A778040
62000	36	(1,417)	80	(3,150)	14	24	14	9,3	22,0	13,8	A777041	A778041
70000	36	(1,417)	80	(3,150)	13	22	13	10,1	22,0	13,9	A777042	A778042
93000	36	(1,417)	104	(4,094)	10	18	10	12,3	22,0	18,0	A777043	A778043
98000	51	(2,008)	62	(2,441)	11	20	11	12,8	25,0	14,0	A777044	A778044
159000	51	(2,008)	81	(3,189)	7	13	7	17,9	25,0	20,0	A777045	A778045
212000	51	(2,008)	104	(4,094)	5	11	5	21,9	25,0	25,0	A777046	A778046
318000	51	(2,008)	144	(5,669)	3	8	3	29,1	25,0	25,0	A777047	A778047
357000	66	(2,598)	104	(4,094)	5	10	5	31,6	50,0	25,8	A777048	A778048
450000	73	(2,874)	104	(4,094)	4	8	4	37,1	55,0	32,2	A777049	A778049
675000	73	(2,874)	144	(5,669)	2	7	2	49,3	55,0	45,4	A777050	A778050
522000	77	(3,031)	104	(4,094)	4	8	4	41,2	55,0	31,7	A777051	A778051
783000	77	(3,031)	144	(5,669)	2	7	2	54,7	55,0	44,6	A777052	A778052
1221000	77	(3,031)	220	(8,661)	2	7	2	74,7	55,0	55,0	A777053	A778053
1118000	90	(3,543)	144	(5,669)	2	6	2	70,2	80,0	51,4	A777054	A778054
1491000	90	(3,543)	200	(7,874)	2	6	2	85,9	80,0	67,6	A777055	A778055
1677000	90	(3,543)	220	(8,661)	2	6	2	93,3	80,0	74,5	A777056	A778056

FELSIK HC

BC - BD

8 000 h / 85°C

Capacitance (μF)	Can		ESR 100 Hz +20°C		Z 10 kHz +20°C Typic ($\text{m}\Omega$)	II +20°C 5 min max. (mA)	I~ 100 Hz		Code			
	\emptyset mm (inches)	H mm (inches)	Typic ($\text{m}\Omega$)	max. ($\text{m}\Omega$)			+40°C max. (A)	+85°C max. (A)	BC	BD		
Rated voltage 40 V												
17800	36	(1,417)	44	(1,732)	35	55	34	5,4	11,3	6,5	A777057	A778057
26000	36	(1,417)	52	(2,047)	24	38	23	7,0	14,8	8,5	A777058	A778058
28700	36	(1,417)	60	(2,362)	22	35	21	7,5	16,4	9,4	A777059	A778059
46000	36	(1,417)	80	(3,150)	13	23	13	10,5	22,0	13,6	A777060	A778060
62000	36	(1,417)	104	(4,094)	10	18	10	12,9	22,0	17,7	A777061	A778061
65000	51	(2,008)	62	(2,441)	11	20	11	13,3	25,0	13,9	A777062	A778062
105000	51	(2,008)	81	(3,189)	7	13	7	18,6	25,0	19,9	A777063	A778063
141000	51	(2,008)	104	(4,094)	5	11	5	22,9	25,0	25,0	A777064	A778064
211000	51	(2,008)	144	(5,669)	3	8	3	30,4	25,0	25,0	A777065	A778065
237000	66	(2,598)	104	(4,094)	5	10	5	32,9	50,0	25,9	A777066	A778066
298000	73	(2,874)	104	(4,094)	4	8	4	38,7	55,0	32,2	A777067	A778067
447000	73	(2,874)	144	(5,669)	2	7	2	51,4	55,0	45,5	A777068	A778068
346000	77	(3,031)	104	(4,094)	4	8	4	42,9	55,0	31,8	A777069	A778069
519000	77	(3,031)	144	(5,669)	2	7	2	57,0	55,0	44,8	A777070	A778070
809000	77	(3,031)	220	(8,661)	3	7	3	77,8	55,0	55,0	A777071	A778071
741000	90	(3,543)	144	(5,669)	2	6	2	73,2	80,0	51,6	A777072	A778072
988000	90	(3,543)	200	(7,874)	2	6	2	89,5	80,0	67,7	A777073	A778073
1111000	90	(3,543)	220	(8,661)	2	6	2	97,2	80,0	74,2	A777074	A778074
Rated voltage 50 V												
9400	36	(1,417)	44	(1,732)	36	57	35	4,0	10,9	5,8	A777075	A778075
14000	36	(1,417)	52	(2,047)	24	39	24	5,3	14,2	7,5	A777076	A778076
15000	36	(1,417)	60	(2,362)	22	36	22	5,6	15,7	8,3	A777077	A778077
25000	36	(1,417)	80	(3,150)	14	24	13	8,0	22,0	12,1	A777078	A778078
33000	36	(1,417)	104	(4,094)	10	18	10	9,7	22,0	15,7	A777079	A778079
34600	51	(2,008)	62	(2,441)	13	22	12	10,0	24,9	11,9	A777080	A778080
37000	51	(2,008)	81	(3,189)	9	17	9	10,5	25,0	18,0	A777081	A778081
56000	51	(2,008)	81	(3,189)	8	15	8	14,0	25,0	17,0	A777082	A778082
75000	51	(2,008)	104	(4,094)	6	12	6	17,2	25,0	21,9	A777083	A778083
112000	51	(2,008)	144	(5,669)	4	9	4	22,8	25,0	25,0	A777084	A778084
126000	66	(2,598)	104	(4,094)	6	12	6	24,8	49,7	21,5	A777085	A778085
158000	73	(2,874)	104	(4,094)	4	10	4	29,0	55,0	26,9	A777086	A778086
237000	73	(2,874)	144	(5,669)	3	7	3	38,5	55,0	37,9	A777087	A778087
184000	77	(3,031)	104	(4,094)	5	10	5	32,3	55,0	26,3	A777088	A778088
275000	77	(3,031)	144	(5,669)	3	8	3	42,7	55,0	37,1	A777089	A778089
430000	77	(3,031)	220	(8,661)	3	7	3	58,4	55,0	54,9	A777090	A778090
393000	90	(3,543)	144	(5,669)	3	7	3	54,9	80,0	42,6	A777091	A778091
524000	90	(3,543)	200	(7,874)	3	7	3	67,1	80,0	57,6	A777092	A778092
590000	90	(3,543)	220	(8,661)	2	6	2	72,9	80,0	62,7	A777093	A778093
Rated voltage 63 V												
6300	36	(1,417)	44	(1,732)	38	60	37	3,6	10,5	5,6	A777094	A778094
9300	36	(1,417)	52	(2,047)	26	42	25	4,7	13,7	7,3	A777095	A778095
10100	36	(1,417)	60	(2,362)	24	39	23	5,0	15,2	8,1	A777096	A778096
16000	36	(1,417)	80	(3,150)	15	25	14	6,9	21,9	11,7	A777097	A778097
22000	36	(1,417)	104	(4,094)	11	19	11	8,6	22,0	15,2	A777098	A778098
23000	51	(2,008)	62	(2,441)	13	23	13	8,8	24,5	11,8	A777099	A778099
37000	51	(2,008)	81	(3,189)	8	15	8	12,3	25,0	16,9	A777100	A778100
50000	51	(2,008)	104	(4,094)	6	12	6	15,2	25,0	21,7	A777101	A778101
75000	51	(2,008)	144	(5,669)	4	9	4	20,2	25,0	25,0	A777102	A778102
83000	66	(2,598)	104	(4,094)	6	12	6	21,7	49,9	21,8	A777103	A778103
105000	73	(2,874)	104	(4,094)	4	10	4	25,6	55,0	27,2	A777104	A778104
158000	73	(2,874)	144	(5,669)	3	7	3	34,1	55,0	38,3	A777105	A778105
122000	77	(3,031)	104	(4,094)	5	10	5	28,4	55,0	26,6	A777106	A778106
183000	77	(3,031)	144	(5,669)	3	8	3	37,8	55,0	37,4	A777107	A778107
286000	77	(3,031)	220	(8,661)	3	7	3	51,6	55,0	54,5	A777108	A778108
261000	90	(3,543)	144	(5,669)	3	7	3	48,4	80,0	43,4	A777109	A778109
349000	90	(3,543)	200	(7,874)	3	7	3	59,4	80,0	57,2	A777110	A778110
392000	90	(3,543)	220	(8,661)	2	6	2	64,4	80,0	62,6	A777111	A778111

8 000 h / 85°C

Capacitance [μF]	Can		ESR 100 Hz +20°C		Z 10 kHz +20°C Typic [mΩ]	II +20°C 5 min max. [mA]	I~ 100 Hz		Code			
	Ø mm (inches)	H mm (inches)	Typic [mΩ]	max. [mΩ]			+40°C max. [A]	+85°C max. [A]	BC	BD		
Rated voltage 80 V												
5300	36	(1,417)	44	(1,732)	39	61	37	3,7	10,4	5,5	A777112	A778112
7900	36	(1,417)	52	(2,047)	26	42	25	5,0	13,6	7,1	A777113	A778113
8600	36	(1,417)	60	(2,362)	24	39	23	5,3	15,0	7,9	A777114	A778114
14000	36	(1,417)	80	(3,150)	15	25	14	7,4	21,8	11,4	A777115	A778115
18000	36	(1,417)	104	(4,094)	11	20	11	8,8	22,0	14,9	A777116	A778116
19000	51	(2,008)	62	(2,441)	13	23	13	9,2	24,3	11,7	A777117	A778117
31000	51	(2,008)	81	(3,189)	8	15	8	12,9	25,0	16,6	A777118	A778118
42000	51	(2,008)	104	(4,094)	6	12	6	15,9	25,0	21,4	A777119	A778119
63000	51	(2,008)	144	(5,669)	4	9	4	21,2	25,0	25,0	A777120	A778120
70000	66	(2,598)	104	(4,094)	6	12	6	22,8	49,5	21,5	A777121	A778121
89000	73	(2,874)	104	(4,094)	5	10	4	27,0	55,0	26,9	A777122	A778122
133000	73	(2,874)	144	(5,669)	3	8	3	35,7	55,0	37,9	A777123	A778123
103000	77	(3,031)	104	(4,094)	5	10	5	29,9	55,0	26,4	A777124	A778124
154000	77	(3,031)	144	(5,669)	3	8	3	39,6	55,0	37,3	A777125	A778125
241000	77	(3,031)	220	(8,661)	3	7	3	54,1	55,0	54,7	A777126	A778126
220000	90	(3,543)	144	(5,669)	3	7	3	50,8	80,0	43,0	A777127	A778127
294000	90	(3,543)	200	(7,874)	3	7	3	62,2	80,0	57,7	A777128	A778128
331000	90	(3,543)	220	(8,661)	2	6	2	67,6	80,0	62,7	A777129	A778129
Rated voltage 100 V												
3300	36	(1,417)	44	(1,732)	43	67	40	3,1	9,7	4,8	A777130	A778130
4900	36	(1,417)	52	(2,047)	29	46	27	4,1	12,6	6,2	A777131	A778131
5300	36	(1,417)	60	(2,362)	26	43	25	4,4	14,0	6,9	A777132	A778132
8700	36	(1,417)	80	(3,150)	16	27	15	6,2	20,3	10,0	A777133	A778133
11700	36	(1,417)	104	(4,094)	12	21	12	7,6	22,0	13,0	A777134	A778134
12000	51	(2,008)	62	(2,441)	16	26	15	7,8	21,9	10,0	A777135	A778135
13000	51	(2,008)	81	(3,189)	11	19	10	8,2	25,0	14,9	A777136	A778136
19700	51	(2,008)	104	(4,094)	10	17	9	11,0	25,0	14,3	A777137	A778137
26000	51	(2,008)	144	(5,669)	7	14	7	13,3	25,0	18,4	A777138	A778138
39000	51	(2,008)	200	(7,874)	5	10	5	17,7	25,0	25,0	A777139	A778139
44000	66	(2,598)	104	(4,094)	8	15	8	19,3	43,1	18,2	A777140	A778140
56000	73	(2,874)	104	(4,094)	6	12	6	22,8	53,5	22,8	A777141	A778141
83000	73	(2,874)	144	(5,669)	4	9	4	30,0	55,0	32,1	A777142	A778142
64000	77	(3,031)	104	(4,094)	6	12	6	25,0	53,2	22,3	A777143	A778143
97000	77	(3,031)	144	(5,669)	4	9	4	33,5	55,0	31,5	A777144	A778144
151000	77	(3,031)	220	(8,661)	3	8	3	45,6	55,0	47,3	A777145	A778145
138000	90	(3,543)	144	(5,669)	3	8	3	42,8	80,0	36,2	A777146	A778146
184000	90	(3,543)	200	(7,874)	3	8	3	52,4	80,0	49,5	A777147	A778147
207000	90	(3,543)	220	(8,661)	3	7	3	56,9	80,0	53,6	A777148	A778148
Rated voltage 120 V												
2100	36	(1,417)	44	(1,732)	47	74	43	2,6	9,1	4,4	A777149	A778149
3100	36	(1,417)	52	(2,047)	32	51	29	3,4	11,9	5,8	A777150	A778150
3300	36	(1,417)	60	(2,362)	30	48	27	3,6	13,1	6,4	A777151	A778151
5400	36	(1,417)	80	(3,150)	18	30	17	5,0	19,0	9,3	A777152	A778152
7300	36	(1,417)	104	(4,094)	14	23	12	6,2	22,0	12,1	A777153	A778153
7600	51	(2,008)	62	(2,441)	17	28	16	6,4	21,1	9,6	A777154	A778154
12000	51	(2,008)	81	(3,189)	10	19	10	8,8	25,0	13,7	A777155	A778155
16000	51	(2,008)	104	(4,094)	8	15	7	10,8	25,0	17,7	A777156	A778156
24700	51	(2,008)	144	(5,669)	5	11	5	14,6	25,0	25,0	A777157	A778157
27700	66	(2,598)	104	(4,094)	8	15	8	15,8	42,5	18,0	A777158	A778158
35000	73	(2,874)	104	(4,094)	6	12	6	18,6	52,5	22,4	A777159	A778159
52000	73	(2,874)	144	(5,669)	4	9	4	24,6	55,0	31,8	A777160	A778160
40000	77	(3,031)	104	(4,094)	6	12	6	20,5	52,6	22,1	A777161	A778161
61000	77	(3,031)	144	(5,669)	4	9	4	27,5	55,0	31,0	A777162	A778162
95000	77	(3,031)	220	(8,661)	3	8	3	37,5	55,0	46,3	A777163	A778163
87000	90	(3,543)	144	(5,669)	3	8	3	35,2	80,0	36,1	A777164	A778164
115000	90	(3,543)	200	(7,874)	2	7	2	42,8	80,0	50,1	A777165	A778165
130000	90	(3,543)	220	(8,661)	3	7	3	46,7	80,0	52,9	A777166	A778166

FELSIC HC

BC - BD

8 000 h / 85°C

Capacitance (μF)	Can		ESR 100 Hz +20°C		Z 10 kHz +20°C Typic ($\text{m}\Omega$)	II +20°C 5 min max. (mA)	I~ 100 Hz		Code			
	\emptyset mm (inches)	H mm (inches)	Typic ($\text{m}\Omega$)	max. ($\text{m}\Omega$)			+40°C max. (A)	+85°C max. (A)	BC	BD		
Rated voltage 160 V												
1400	36	(1,417)	44	(1,732)	54	84	48	2,4	8,5	4,1	A777167	A778167
2100	36	(1,417)	52	(2,047)	37	58	32	3,2	11,0	5,3	A777168	A778168
2300	36	(1,417)	60	(2,362)	34	53	30	3,4	12,2	5,9	A777169	A778169
3800	36	(1,417)	80	(3,150)	21	34	18	4,8	17,7	8,5	A777170	A778170
5100	36	(1,417)	104	(4,094)	24	39	22	5,9	19,4	10,2	A777171	A778171
5300	51	(2,008)	62	(2,441)	18	31	17	6,1	20,0	9,1	A777172	A778172
8600	51	(2,008)	81	(3,189)	11	20	10	8,5	25,0	13,0	A777173	A778173
11000	51	(2,008)	104	(4,094)	9	16	8	10,1	25,0	16,7	A777174	A778174
17000	51	(2,008)	144	(5,669)	6	12	5	13,8	25,0	23,7	A777175	A778175
19000	66	(2,598)	104	(4,094)	8	15	8	14,9	41,6	17,7	A777176	A778176
24000	73	(2,874)	104	(4,094)	6	12	6	17,5	51,3	22,0	A777177	A778177
36000	73	(2,874)	144	(5,669)	4	9	4	23,2	55,0	31,1	A777178	A778178
28000	77	(3,031)	104	(4,094)	6	13	6	19,5	51,7	21,9	A777179	A778179
42000	77	(3,031)	144	(5,669)	4	9	4	25,9	55,0	30,8	A777180	A778180
66000	77	(3,031)	220	(8,661)	4	8	3	35,5	55,0	43,3	A777181	A778181
60000	90	(3,543)	144	(5,669)	4	8	3	33,2	80,0	35,9	A777182	A778182
80000	90	(3,543)	200	(7,874)	3	8	3	40,7	80,0	48,5	A777183	A778183
91000	90	(3,543)	220	(8,661)	3	7	3	44,5	80,0	52,7	A777184	A778184
Rated voltage 200 V												
1200	36	(1,417)	44	(1,732)	58	90	50	2,5	8,1	3,9	A777185	A778185
1780	36	(1,417)	52	(2,047)	39	62	34	3,3	10,6	5,0	A777186	A778186
2000	36	(1,417)	60	(2,362)	36	57	31	3,6	11,8	5,6	A777187	A778187
2200	36	(1,417)	80	(3,150)	27	44	24	3,8	15,5	7,5	A777188	A778188
3200	36	(1,417)	80	(3,150)	22	36	19	5,0	17,0	8,1	A777189	A778189
4200	36	(1,417)	104	(4,094)	17	28	15	6,0	22,0	10,5	A777190	A778190
4400	51	(2,008)	62	(2,441)	19	32	17	6,2	19,4	8,8	A777191	A778191
7200	51	(2,008)	81	(3,189)	12	21	11	8,8	25,0	12,5	A777192	A778192
9600	51	(2,008)	104	(4,094)	9	17	8	10,8	25,0	16,2	A777193	A778193
14000	51	(2,008)	144	(5,669)	6	12	5	14,0	25,0	22,9	A777194	A778194
16000	66	(2,598)	104	(4,094)	9	16	8	15,4	40,9	17,4	A777195	A778195
20000	73	(2,874)	104	(4,094)	6	13	6	18,0	50,4	21,6	A777196	A778196
30000	73	(2,874)	144	(5,669)	4	9	4	23,9	55,0	30,5	A777197	A778197
23600	77	(3,031)	104	(4,094)	7	13	6	20,2	50,9	21,5	A777198	A778198
35000	77	(3,031)	144	(5,669)	4	10	4	26,6	55,0	30,4	A777199	A778199
55000	77	(3,031)	220	(8,661)	4	9	4	36,6	55,0	44,9	A777200	A778200
50000	90	(3,543)	144	(5,669)	4	8	3	34,2	80,0	35,4	A777201	A778201
45000	90	(3,543)	200	(7,874)	3	8	3	31,8	80,0	49,8	A777202	A778202
67000	90	(3,543)	200	(7,874)	3	8	3	42,0	80,0	47,8	A777203	A778203
76000	90	(3,543)	220	(8,661)	3	7	3	45,8	80,0	52,2	A777204	A778204
Rated voltage 250 V												
780	36	(1,417)	44	(1,732)	69	107	59	2,2	7,4	3,5	A777205	A778205
1200	36	(1,417)	52	(2,047)	46	71	39	2,9	9,8	4,6	A777206	A778206
1300	36	(1,417)	60	(2,362)	42	66	36	3,1	10,8	5,1	A777207	A778207
2100	36	(1,417)	80	(3,150)	26	42	22	4,4	15,6	7,3	A777208	A778208
2900	36	(1,417)	104	(4,094)	19	32	16	5,5	20,6	9,6	A777209	A778209
3000	51	(2,008)	62	(2,441)	22	36	19	5,6	18,3	8,3	A777210	A778210
4900	51	(2,008)	81	(3,189)	13	23	12	7,9	25,0	11,8	A777211	A778211
6400	51	(2,008)	104	(4,094)	10	18	9	9,5	25,0	15,2	A777212	A778212
9700	51	(2,008)	144	(5,669)	7	13	6	12,7	25,0	21,6	A777213	A778213
10900	66	(2,598)	104	(4,094)	9	17	8	13,8	39,9	17,1	A777214	A778214
13700	73	(2,874)	104	(4,094)	7	13	6	16,2	49,0	21,1	A777215	A778215
20000	73	(2,874)	144	(5,669)	5	10	4	21,1	55,0	29,9	A777216	A778216
16000	77	(3,031)	104	(4,094)	7	13	6	18,0	49,8	21,1	A777217	A778217
24000	77	(3,031)	144	(5,669)	5	10	4	23,9	55,0	29,8	A777218	A778218
37000	77	(3,031)	220	(8,661)	4	9	4	32,4	55,0	43,6	A777219	A778219
34000	90	(3,543)	144	(5,669)	4	9	4	30,5	80,0	35,2	A777220	A778220
45000	90	(3,543)	200	(7,874)	3	8	3	37,1	80,0	46,6	A777221	A778221
51000	90	(3,543)	220	(8,661)	3	7	3	40,5	80,0	51,3	A777222	A778222

8 000 h / 85°C

Capacitance [μF]	Can		ESR 100 Hz +20°C		Z 10 kHz +20°C Typic [mΩ]	II +20°C 5 min max. [mA]	I~ 100 Hz		Code			
	∅ mm (inches)	H mm (inches)	Typic [mΩ]	max. [mΩ]			+40°C max. [A]	+85°C max. [A]	BC	BD		
Rated voltage 300 V												
650	36	(1,417)	44	(1,732)	213	322	187	2,2	4,4	2,5	A777223	A778223
1000	36	(1,417)	52	(2,047)	139	211	122	2,9	5,8	3,3	A777224	A778224
1100	36	(1,417)	60	(2,362)	126	192	111	3,1	6,5	3,7	A777225	A778225
1890	36	(1,417)	80	(3,150)	74	114	65	4,6	9,6	5,4	A777226	A778226
2400	36	(1,417)	104	(4,094)	58	90	51	5,4	12,3	6,9	A777227	A778227
2550	51	(2,008)	62	(2,441)	58	90	52	5,7	11,7	6,4	A777228	A778228
4200	51	(2,008)	81	(3,189)	35	56	32	8,0	16,8	9,1	A777229	A778229
5550	51	(2,008)	104	(4,094)	27	43	24	9,8	21,6	11,7	A777230	A778230
8300	51	(2,008)	144	(5,669)	18	30	16	12,9	25,0	16,6	A777231	A778231
9300	66	(2,598)	104	(4,094)	19	32	17	14,0	28,8	14,4	A777232	A778232
11800	73	(2,874)	104	(4,094)	15	25	13	16,5	34,9	17,6	A777233	A778233
17700	73	(2,874)	144	(5,669)	10	18	9	22,0	49,2	24,8	A777234	A778234
13700	77	(3,031)	104	(4,094)	14	24	13	18,4	36,9	18,1	A777235	A778235
20600	77	(3,031)	144	(5,669)	9	17	8	24,4	52,0	25,5	A777236	A778236
25800	77	(3,031)	220	(8,661)	7	13	6	28,6	55,0	37,6	A777237	A778237
23700	90	(3,543)	144	(5,669)	8	14	7	26,9	62,7	31,2	A777238	A778238
31600	90	(3,543)	200	(7,874)	6	12	5	32,9	80,0	41,4	A777239	A778239
35000	90	(3,543)	220	(8,661)	5	11	5	35,4	80,0	45,8	A777240	A778240
Rated voltage 350 V												
550	36	(1,417)	44	(1,732)	206	313	176	2,2	4,4	2,4	A777241	A778241
780	36	(1,417)	52	(2,047)	145	220	124	2,8	5,6	3,1	A777242	A778242
890	36	(1,417)	60	(2,362)	128	194	109	3,0	6,4	3,5	A777243	A778243
1050	36	(1,417)	80	(3,150)	99	152	85	3,4	8,3	4,6	A777244	A778244
1400	36	(1,417)	80	(3,150)	81	124	69	4,1	9,1	5,0	A777245	A778245
1890	36	(1,417)	104	(4,094)	60	93	51	5,1	11,9	6,5	A777246	A778246
2000	51	(2,008)	62	(2,441)	61	94	52	5,3	11,4	6,0	A777247	A778247
2067	51	(2,008)	81	(3,189)	54	84	46	5,4	13,6	7,5	A777248	A778248
3100	51	(2,008)	81	(3,189)	39	61	33	7,2	16,0	8,5	A777249	A778249
4200	51	(2,008)	104	(4,094)	29	46	25	8,9	20,7	11,0	A777250	A778250
4200	51	(2,008)	144	(5,669)	27	43	23	8,9	25,0	13,6	A777251	A778251
6300	51	(2,008)	144	(5,669)	19	32	16	11,9	25,0	15,6	A777252	A778252
7100	66	(2,598)	104	(4,094)	20	33	18	12,9	27,9	13,7	A777253	A778253
8900	73	(2,874)	104	(4,094)	16	27	14	15,1	33,7	16,7	A777254	A778254
13000	73	(2,874)	144	(5,669)	12	21	11	19,7	44,8	23,0	A777255	A778255
10300	77	(3,031)	104	(4,094)	15	25	13	16,7	35,7	17,3	A777256	A778256
15000	77	(3,031)	144	(5,669)	10	18	9	21,8	50,1	24,4	A777257	A778257
19000	77	(3,031)	220	(8,661)	7	14	7	25,7	55,0	35,7	A777258	A778258
17900	90	(3,543)	144	(5,669)	8	15	7	24,7	60,7	29,8	A777259	A778259
23800	90	(3,543)	200	(7,874)	6	12	6	30,1	80,0	39,5	A777260	A778260
26800	90	(3,543)	220	(8,661)	6	11	5	32,7	80,0	43,8	A777261	A778261
Rated voltage 385 V												
400	36	(1,417)	44	(1,732)	270	408	229	1,8	3,9	2,1	A777262	A778262
670	36	(1,417)	52	(2,047)	163	247	138	2,6	5,3	2,9	A777263	A778263
670	36	(1,417)	60	(2,362)	162	246	137	2,6	5,7	3,1	A777264	A778264
1100	36	(1,417)	80	(3,150)	99	151	84	3,7	8,3	4,5	A777265	A778265
1560	36	(1,417)	104	(4,094)	70	108	59	4,8	11,1	6,1	A777266	A778266
1560	51	(2,008)	62	(2,441)	73	112	62	4,8	10,5	5,6	A777267	A778267
2560	51	(2,008)	81	(3,189)	44	69	38	6,8	15,0	8,0	A777268	A778268
3400	51	(2,008)	104	(4,094)	33	53	29	8,2	19,3	10,3	A777269	A778269
5100	51	(2,008)	144	(5,669)	22	36	19	10,9	25,0	14,7	A777270	A778270
5800	66	(2,598)	104	(4,094)	22	37	20	12,0	26,8	13,5	A777271	A778271
7200	73	(2,874)	104	(4,094)	18	29	15	13,9	32,1	16,3	A777272	A778272
10900	73	(2,874)	144	(5,669)	12	20	10	18,6	45,4	23,1	A777273	A778273
8400	77	(3,031)	104	(4,094)	16	27	14	15,5	34,5	17,2	A777274	A778274
12700	77	(3,031)	144	(5,669)	11	19	9	20,7	48,7	24,2	A777275	A778275
18000	77	(3,031)	220	(8,661)	8	14	7	26,5	55,0	35,5	A777276	A778276
16700	90	(3,543)	144	(5,669)	8	15	7	25,1	60,1	29,6	A777277	A778277
15000	90	(3,543)	200	(7,874)	8	15	7	23,3	70,6	37,1	A777278	A778278
22000	90	(3,543)	200	(7,874)	6	13	6	30,4	78,9	39,3	A777279	A778279
25000	90	(3,543)	220	(8,661)	6	12	5	33,3	80,0	43,5	A777280	A778280

FELSIK HC

BC - BD

8 000 h / 85°C

Capacitance (μF)	Can		ESR 100 Hz +20°C		Z 10 kHz +20°C Typic ($\text{m}\Omega$)	II +20°C 5 min max. (mA)	I~ 100 Hz		Code			
	\emptyset mm (inches)	H mm (inches)	Typic ($\text{m}\Omega$)	max. ($\text{m}\Omega$)			+40°C max. (A)	+85°C max. (A)	BC	BD		
Rated voltage 400 V												
400	36	(1,417)	44	(1,732)	270	408	229	1,9	3,9	2,1	A777281	A778281
670	36	(1,417)	52	(2,047)	163	247	138	2,7	5,3	2,9	A777282	A778282
670	36	(1,417)	60	(2,362)	162	246	137	2,7	5,7	3,1	A777283	A778283
1100	36	(1,417)	80	(3,150)	99	151	84	3,8	8,3	4,5	A777284	A778284
1550	36	(1,417)	104	(4,094)	70	108	60	4,9	11,0	6,1	A777285	A778285
1550	51	(2,008)	62	(2,441)	73	113	62	4,9	10,4	5,6	A777286	A778286
1900	51	(2,008)	81	(3,189)	56	87	48	5,6	13,4	7,3	A777287	A778287
2550	51	(2,008)	81	(3,189)	44	70	38	6,9	15,0	8,0	A777288	A778288
3400	51	(2,008)	104	(4,094)	33	53	29	8,5	19,3	10,3	A777289	A778289
5100	51	(2,008)	144	(5,669)	22	36	19	11,2	25,0	14,7	A777290	A778290
5800	66	(2,598)	104	(4,094)	22	37	20	12,3	26,8	13,5	A777291	A778291
7200	73	(2,874)	104	(4,094)	18	29	15	14,3	32,1	16,3	A777292	A778292
10900	73	(2,874)	144	(5,669)	14	24	12	15,7	41,3	21,6	A777293	A778293
10900	73	(2,874)	144	(5,669)	12	20	10	19,1	45,4	23,1	A777294	A778294
8400	77	(3,031)	104	(4,094)	16	27	14	15,9	34,5	17,2	A777295	A778295
12700	77	(3,031)	144	(5,669)	11	19	9	21,3	48,7	24,2	A777296	A778296
18000	77	(3,031)	220	(8,661)	8	14	7	27,2	55,0	35,5	A777297	A778297
16700	90	(3,543)	144	(5,669)	8	15	7	25,8	60,1	29,6	A777298	A778298
16500	90	(3,543)	200	(7,874)	8	15	7	25,6	78,9	39,3	A777299	A778299
22000	90	(3,543)	200	(7,874)	6	13	6	31,3	78,9	39,3	A777300	A778300
25000	90	(3,543)	220	(8,661)	6	12	5	34,2	80,0	43,5	A777301	A778301
Rated voltage 450 V												
330	36	(1,417)	44	(1,732)	285	430	715	1,8	3,7	2,0	A777302	A778302
560	36	(1,417)	52	(2,047)	169	257	426	2,6	5,2	2,8	A777303	A778303
560	36	(1,417)	60	(2,362)	168	256	424	2,6	5,5	3,0	A777304	A778304
890	36	(1,417)	80	(3,150)	106	162	268	3,6	7,9	4,2	A777305	A778305
1200	36	(1,417)	104	(4,094)	79	121	199	4,4	10,4	5,6	A777306	A778306
1300	51	(2,008)	62	(2,441)	76	117	192	4,7	10,2	5,3	A777307	A778307
1400	51	(2,008)	81	(3,189)	67	104	172	4,9	12,1	6,5	A777308	A778308
2100	51	(2,008)	81	(3,189)	47	73	120	6,6	14,5	7,6	A777309	A778309
2780	51	(2,008)	104	(4,094)	35	56	91	8,0	18,6	9,7	A777310	A778310
4100	51	(2,008)	144	(5,669)	24	39	63	10,5	25,0	13,8	A777311	A778311
4670	66	(2,598)	104	(4,094)	24	39	62	11,5	25,8	12,9	A777312	A778312
5900	73	(2,874)	104	(4,094)	18	31	49	13,5	31,1	15,6	A777313	A778313
5900	73	(2,874)	144	(5,669)	17	28	45	13,5	38,0	19,8	A777314	A778314
8800	73	(2,874)	144	(5,669)	12	22	34	17,9	43,8	22,0	A777315	A778315
6800	77	(3,031)	104	(4,094)	17	28	45	14,9	33,4	16,4	A777316	A778316
10200	77	(3,031)	144	(5,669)	11	20	31	19,8	47,0	23,2	A777317	A778317
14800	77	(3,031)	220	(8,661)	8	15	23	25,7	55,0	34,0	A777318	A778318
13600	90	(3,543)	144	(5,669)	9	16	25	24,3	58,3	28,5	A777319	A778319
18000	90	(3,543)	200	(7,874)	7	13	20	29,5	76,7	37,8	A777320	A778320
20000	90	(3,543)	220	(8,661)	6	12	18	31,8	80,0	41,8	A777321	A778321
Rated voltage 500 V												
100	36	(1,417)	44	(1,732)	1508	2265	1353	0,8	1,6	0,9	A777322	A778322
200	36	(1,417)	52	(2,047)	755	1136	678	1,4	2,5	1,3	A777323	A778323
200	36	(1,417)	60	(2,362)	755	1135	678	1,4	2,6	1,4	A777324	A778324
400	36	(1,417)	80	(3,150)	387	583	347	2,2	4,2	2,2	A777325	A778325
560	36	(1,417)	104	(4,094)	290	438	260	2,8	5,5	2,9	A777326	A778326
670	51	(2,008)	62	(2,441)	281	425	252	3,2	5,4	2,8	A777327	A778327
1000	51	(2,008)	81	(3,189)	173	263	156	4,2	7,7	4,0	A777328	A778328
1300	51	(2,008)	104	(4,094)	130	198	117	5,1	9,9	5,2	A777329	A778329
2000	51	(2,008)	144	(5,669)	87	133	78	6,8	14,0	7,4	A777330	A778330
2200	66	(2,598)	104	(4,094)	79	122	71	7,3	14,6	7,6	A777331	A778331
2900	73	(2,874)	104	(4,094)	63	97	56	8,9	17,4	9,1	A777332	A778332
4300	73	(2,874)	144	(5,669)	42	66	38	11,7	24,5	12,8	A777333	A778333
3300	77	(3,031)	104	(4,094)	48	75	43	9,7	20,5	10,6	A777334	A778334
5000	77	(3,031)	144	(5,669)	32	50	28	13,0	29,0	15,0	A777335	A778335
7600	77	(3,031)	220	(8,661)	21	34	19	17,4	43,2	22,4	A777336	A778336
7000	90	(3,543)	144	(5,669)	23	37	21	16,4	37,1	19,1	A777337	A778337
9300	90	(3,543)	200	(7,874)	17	29	15	20,0	49,5	25,5	A777338	A778338
10600	90	(3,543)	220	(8,661)	15	26	14	21,9	55,1	28,4	A777339	A778339

8 000 h / 85°C

PEAK VOLTAGE (V)

1000 cycles, without ripple current

Up: Repetitive standard peak voltage (30 s)

Us: Repetitive surge voltage (0,1 s)

Do not overstep this value without damage.

U _R	10 V	16 V	25 V	40 V	50 V	63 V	80 V	100 V	160 V	200 V
U _p	11,5	18	29	46	58	72	92	115	184	230
U _s										200 235

U _R	250 V	305 V	350 V	360 V	385 V	400 V	410 V	415 V	450 V	460 V	500 V
U _p	288	330	385	390	424	440	450	457	495	506	550
U _s	290	335	405	405	430	450	468	468	500	540	600

PERMISSIBLE REPETITIVE PEAK CURRENT I_p:

If given corresponding max r.m.s. currents are not exceeded, peak current values are as follows:

DIMENSIONS in mm (inches)				I _p (A)		I max.
Ø	H			40°C	85°C	(A)
36	(1,417)	44	(1,732)	330	170	22
36	(1,417)	52	(2,047)	400	200	22
36	(1,417)	60	(2,362)	450	220	22
36	(1,417)	80	(3,150)	600	300	22
36	(1,417)	104	(4,094)	700	400	22
51	(2,008)	62	(2,441)	700	400	25
51	(2,008)	81	(3,189)	800	400	25
51	(2,008)	104	(4,094)	1100	500	25
51	(2,008)	144	(5,669)	1300	600	25
66	(2,598)	104	(4,094)	1900	800	50
73	(2,874)	104	(4,094)	3000	1100	55
73	(2,874)	144	(5,669)	4000	1700	55
77	(3,031)	104	(4,094)	3100	1200	55
77	(3,031)	144	(5,669)	4200	1800	55
77	(3,031)	220	(8,661)	5700	2400	55
90	(3,543)	144	(5,669)	5700	2400	80
90	(3,543)	200	(7,874)	7700	3200	80

CONNECTIONS IN SERIES:

Operating voltages exceeding 500 V up to 20000 V will be reached by connecting capacitors with rated voltages higher or equal to 350 V in series.

EXPECTED LIFE

as a function of temperature and ripple current:

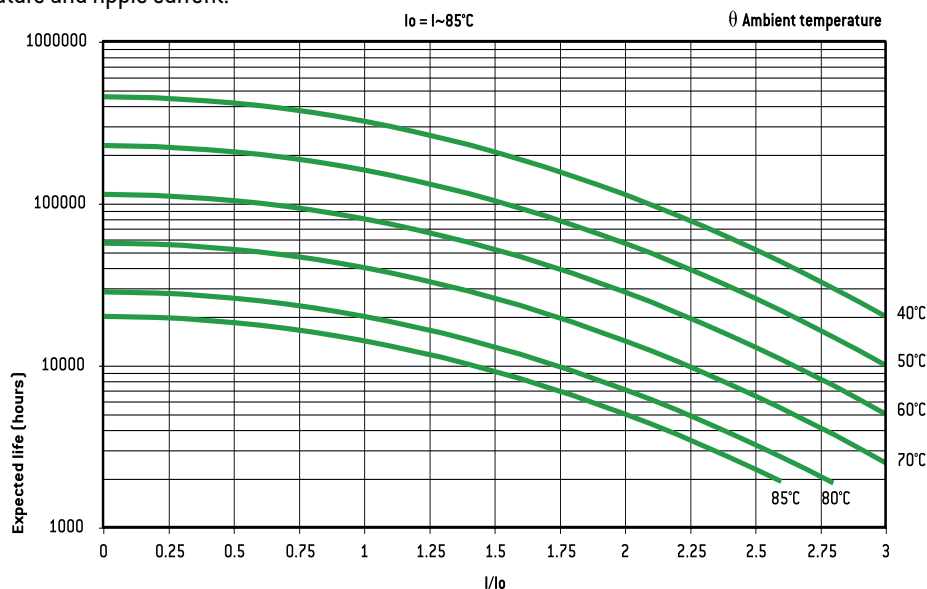

EXPECTED LIFE WITH ID:

- 1 to 5 discharges per minute For I = I_d 48 000 000 cycles
- 10 discharges per minute For I = I_d 36 000 000 cycles
- 15 discharges per minute For I = I_d 18 000 000 cycles

$$I = I_d/2 > 1 \times 10^9 \text{ cycles}$$

- 15 to 60 discharges per minute

To have the highest dissipated power, use preferably FELSIC HC 500 V and calculate r.m.s. current (general technical data § 6.4.2.).

In order to have the highest value of stored energy use preferably FELSIC HC 305 V, 360 V, 410 V and 460 V (0.4 Wh/kg).

FAST DISCHARGES WORKING (ID)

Discharge current I_d = peak current of 3 ms per cycle of 1 to 60 s, at 40°C.I_d as a function of case

DIMENSIONS in mm (inches)				I _d
Ø	H			(A)
36	(1,417)	44	(1,732)	200
36	(1,417)	52	(2,047)	230
36	(1,417)	60	(2,362)	300
36	(1,417)	80	(3,150)	440
36	(1,417)	104	(4,094)	580
51	(2,008)	62	(2,441)	600
51	(2,008)	81	(3,189)	740
51	(2,008)	104	(4,094)	990
51	(2,008)	144	(5,669)	1280
66	(2,598)	104	(4,094)	1400
73	(2,874)	104	(4,094)	1570
73	(2,874)	144	(5,669)	2200
77	(3,031)	104	(4,094)	2000
77	(3,031)	144	(5,669)	2800
77	(3,031)	220	(8,661)	3700
90	(3,543)	144	(5,669)	3900
90	(3,543)	200	(7,874)	4800

PERMISSIBLE RIPPLE CURRENT I (R.M.S. VALUE)

versus frequency f:

I ~: permissible r.m.s. current at 100 Hz

f (Hz)	50	100	300	600	1 000	10 000	≥ 50 000
I	0,8 x I	I	1,2 x I	1,3 x I	1,35 x I	1,5 x I	1,6 x I